

## **APPENDIX D: Supporting Plans**

C17\_LAN\_002 Phase 1\_Establishment\_Rev A

C17\_LAN\_002 Phase 2\_Mineral\_Working Rev A

C17\_LAN\_004 Cross Sections\_Rev A

C17\_LAN\_008 Initial Site Management Compound

JNY10850-07 Proposed Slough Road Access.

JNY10850-16a



- LEGEND**
- Application Boundary
  - Woodland, hedge and tree
  - Road
  - Water course and body
  - Public Right of Way
  - Diversion of Public Right of Way
  - Temporary access road from A4007 to establishment works
  - Proposed M25 slip roads
  - Vehicle access to west of M25
  - Initial construction compound for mineral working
  - Temporary soil storage mound
  - Temporary overburden storage mound

**NOTES:**  
 Revision A - Annotation added re details of Site Management Area; open channel collecting spring water added earlier in programme

**INFORMATION**

0 200  
 metres  
Ordnance Survey © Crown Copyright, 2021. All Rights Reserved. Licence No. 0100031673

**CLIENT**

**Colne Valley MSA Ltd**

---

**PROJECT**

Colne Valley Services - Mineral Application

---

**TITLE**

**Phase I - Establishment**

---

SCALE	DRAWN BY	DATE
I:2000@ A1	KH/KB	Mar 2022
DRAWING NUMBER	REV	
C17_LAN_002	A	

**ESP Ltd**  
 The Creative Industries Centre  
 Glaston Drive  
 Wolverhampton  
 WV10 9TG  
 Tel: 01902 771311

**ESP**  
 Chartered Surveyors  
 Chartered Landscape Architects  
 Environmental Consultants  
 Health and Safety Consultants

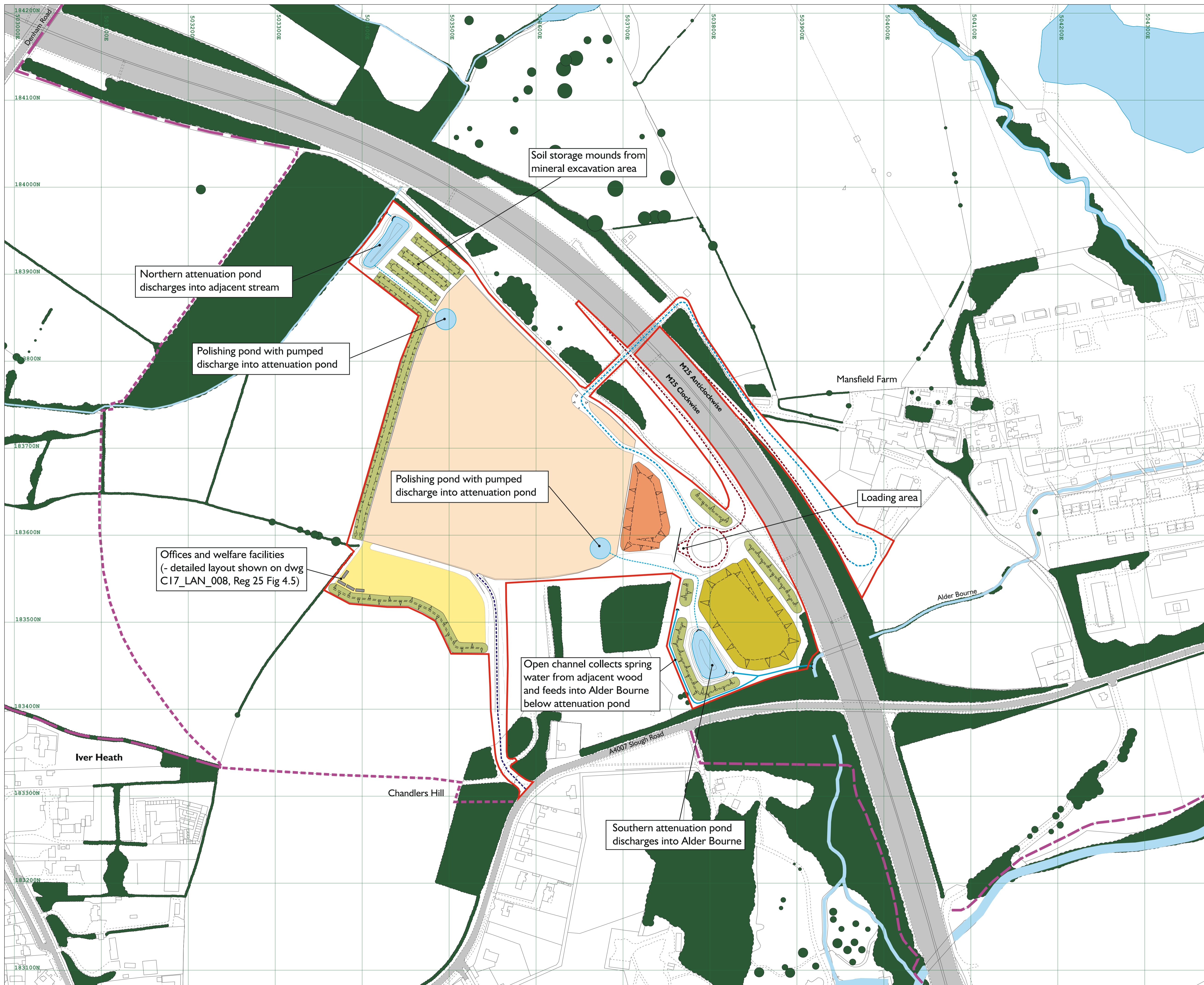

- LEGEND**
- Application Boundary
  - Woodland, hedge and tree
  - Road
  - Water course and body
  - Public Right of Way
  - Diversion of Public Right of Way
  - Temporary access road from A4007 to establishment works
  - Proposed M25 slip road
  - Vehicle access to west of M25
  - Initial construction compound for mineral working
  - Mineral void
  - Soil storage mound
  - Overburden storage mound
  - Staging area for transfer of mineral to HGVs

**NOTES:**  
 Revision A - Addition of soil storage mounds from extraction area; addition of water management details

**INFORMATION**

0 200  
 metres  
Ordnance Survey © Crown Copyright, 2021. All Rights Reserved. Licence No. 0100031673

**CLIENT**

**Colne Valley MSA Ltd**

**ESP Ltd**  
 The Creative Industries Centre  
 Glazier Drive  
 Wolverhampton  
 WV10 9TG  
 Tel: 01902 771311

**PROJECT**

Colne Valley Services - Mineral Application



**TITLE**

**Phase 2 - Mineral Working**

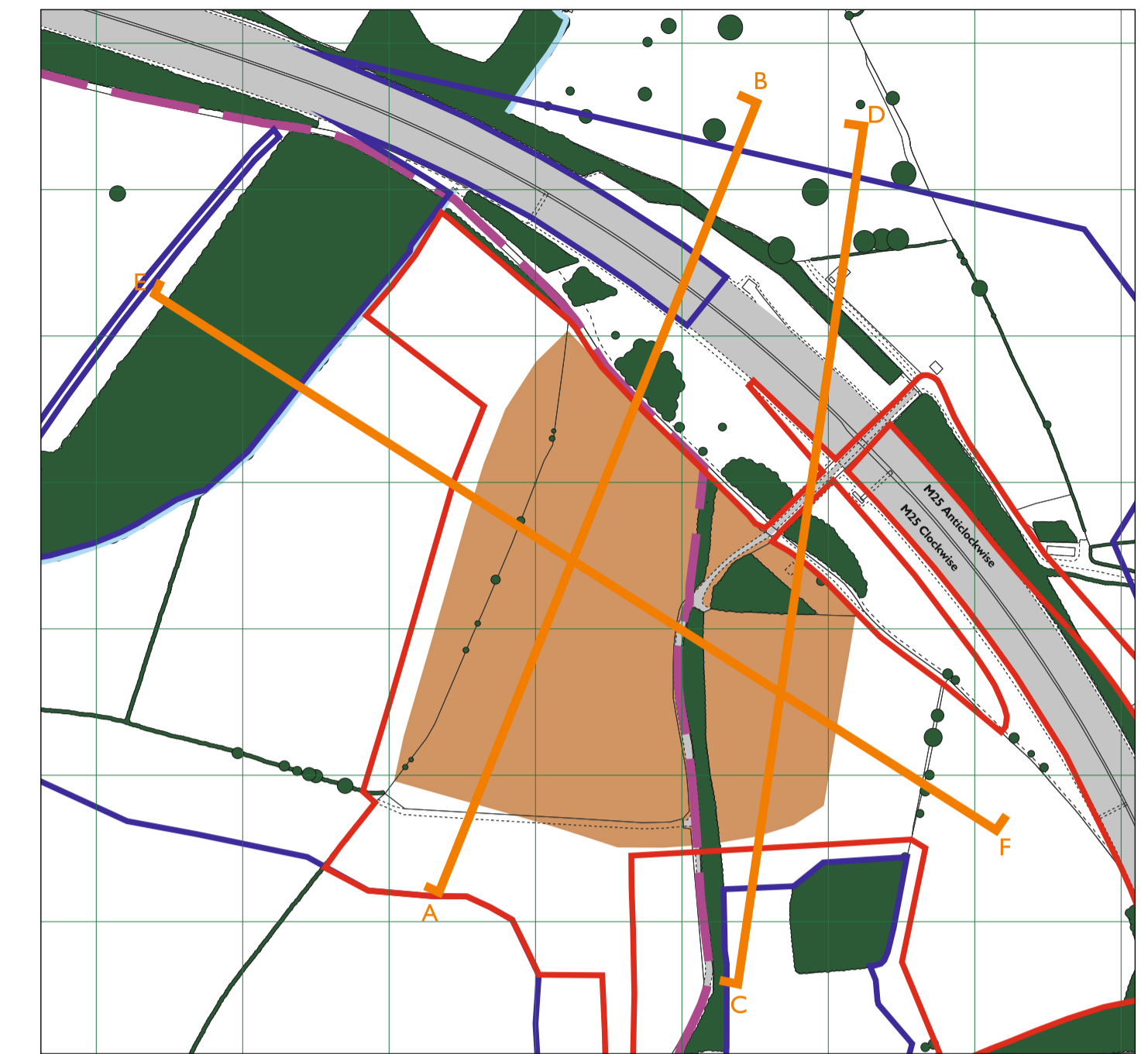
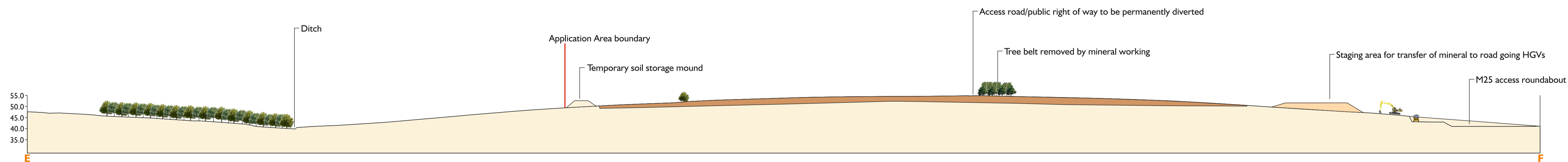
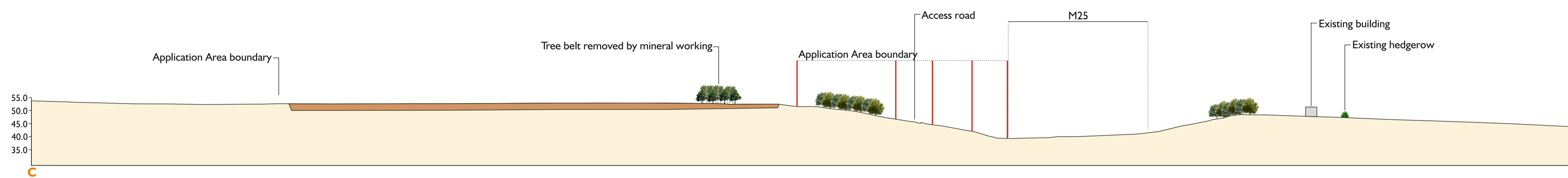
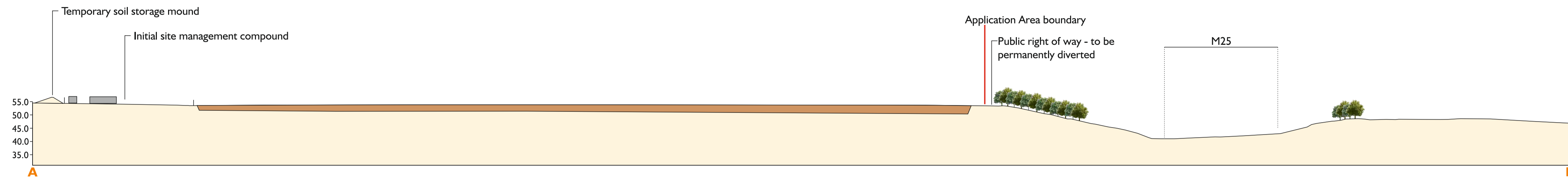
SCALE	DRAWN BY	DATE
1:2000@ A1	KH/KB	Mar 2022
DRAWING NUMBER	REV	
C17_LAN_003	A	



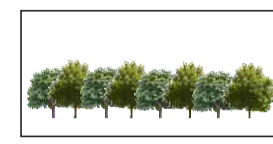

**LEGEND**

-  Mineral to be excavated
-  Existing vegetation
-  Temporary mineral stock pile in staging area for transfer to road going HGVs

**NOTES:**

Revision A - Addition of soil storage mounds from extraction area and site management portacabins

<b>INFORMATION</b>		 	
<b>CLIENT</b>			
Colne Valley MSA Ltd		Chartered Surveyors Chartered Landscape Architects Environmental Consultants Health and Safety Consultants The Creative Industries Centre Glasher Drive Wolverhampton WV10 9TG Tel: 01902 771311	
<b>PROJECT</b>			
Colne Valley Services - Mineral Application			
<b>TITLE</b>			
Cross Sections			
<b>SCALE</b>	<b>DRAWN BY</b>	<b>DATE</b>	
1:1000 @A1	KH/KB	Feb 2022	
<b>DRAWING NUMBER</b>	<b>REV</b>		
C17_LAN_004	A		

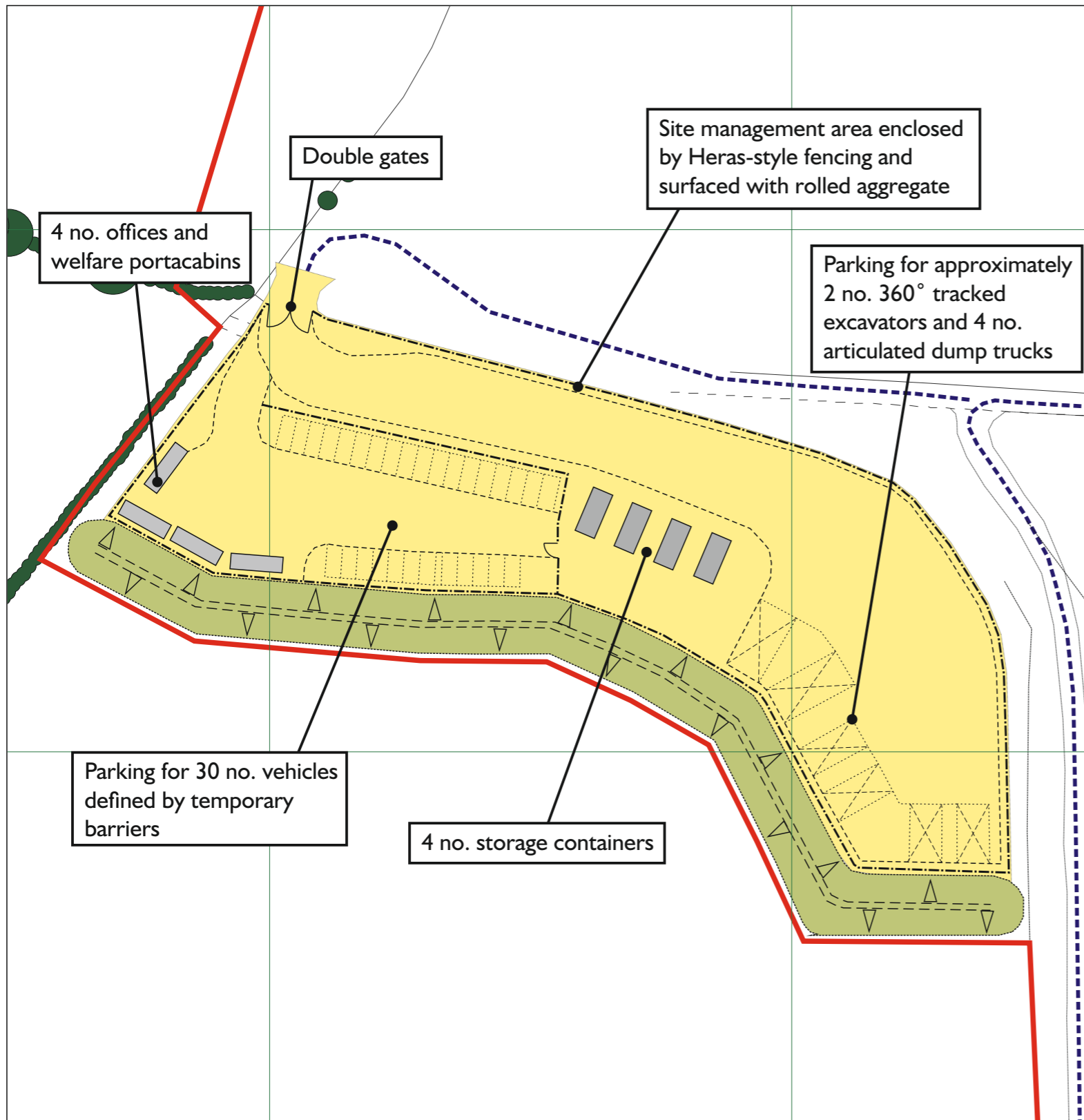

**Office and welfare portacabins**

Pre-fabricated steel painted dove grey,  
1:100

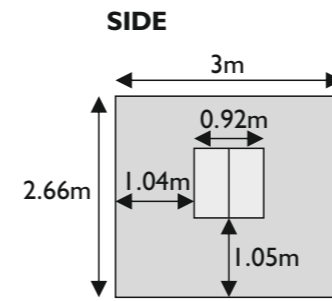

**FRONT**

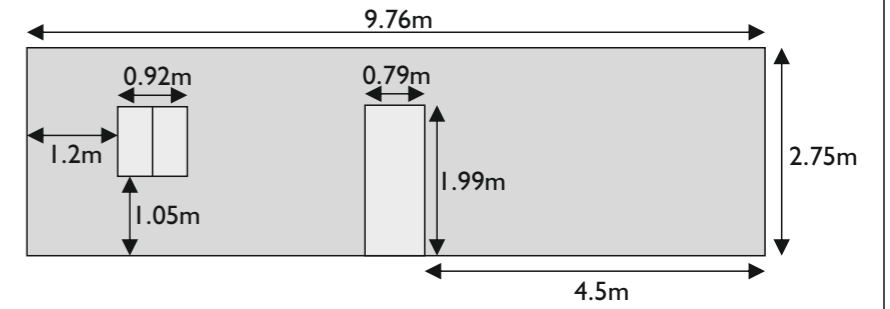

**BACK**

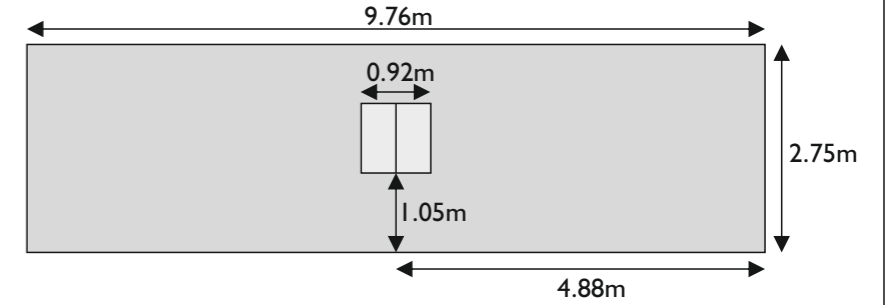

**Storage containers**

Pre-fabricated steel painted dove grey,  
1:100

**FRONT**

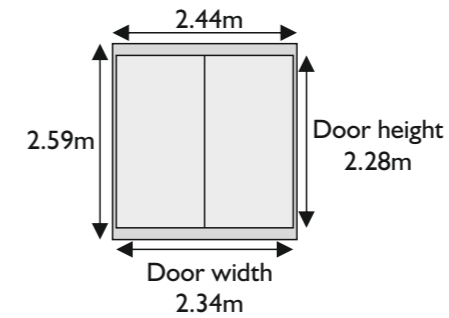

**BACK**

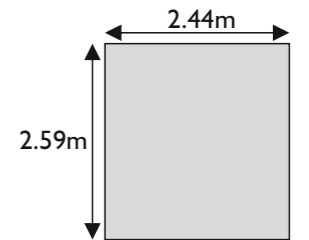

**SIDE**

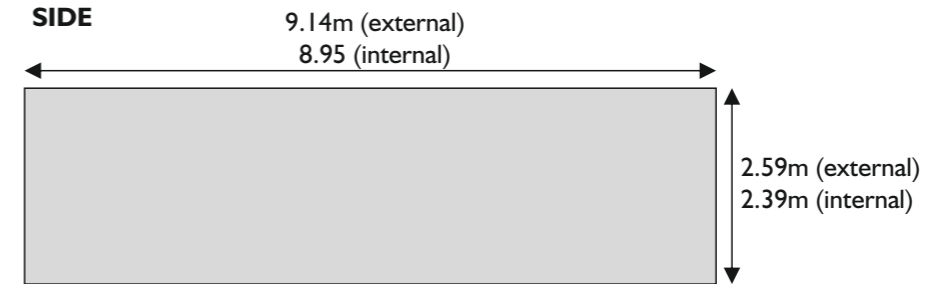

<p><b>INFORMATION</b></p> <p>0  50</p> <p>metres</p> <p>Ordnance Survey © Crown Copyright, 2022. All Rights Reserved. Licence No.0100031673</p>		<p><b>ESP Ltd</b></p> <p>Chartered Surveyors Chartered Landscape Architects Environmental Consultants Health and Safety Consultants</p> <p>The Creative Industries Centre Glaisher Drive Wolverhampton WV10 9TG</p> <p>Tel: 01902 771311</p>
<p><b>CLIENT</b></p> <p><b>Colne Valley MSA Ltd</b></p>		<p><b>PROJECT</b></p> <p>Colne Valley Services - Mineral Application</p>
<p><b>TITLE</b></p> <p><b>Initial Site Management Compound</b></p>		<p><b>SCALE</b>    <b>DRAWN BY</b>    <b>DATE</b></p> <p>1:1000 @A3    KH/KB    Feb 2022</p> <p><b>DRAWING NUMBER</b>    <b>REV</b></p> <p>C17_LAN_008</p>

NOTES

1. This drawing has been prepared in accordance with the scope of RPS's appointment with its client and is subject to the terms and conditions of that appointment. RPS accepts no liability for any use of this document other than by its client and only for the purposes for which it was prepared and provided.
2. If received electronically it is the recipient's responsibility to print to correct scale. Only written dimensions should be used.
3. This drawing is to be read in conjunction with all relevant scheme drawings.

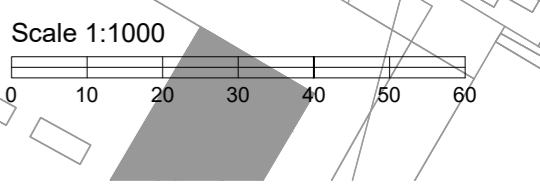
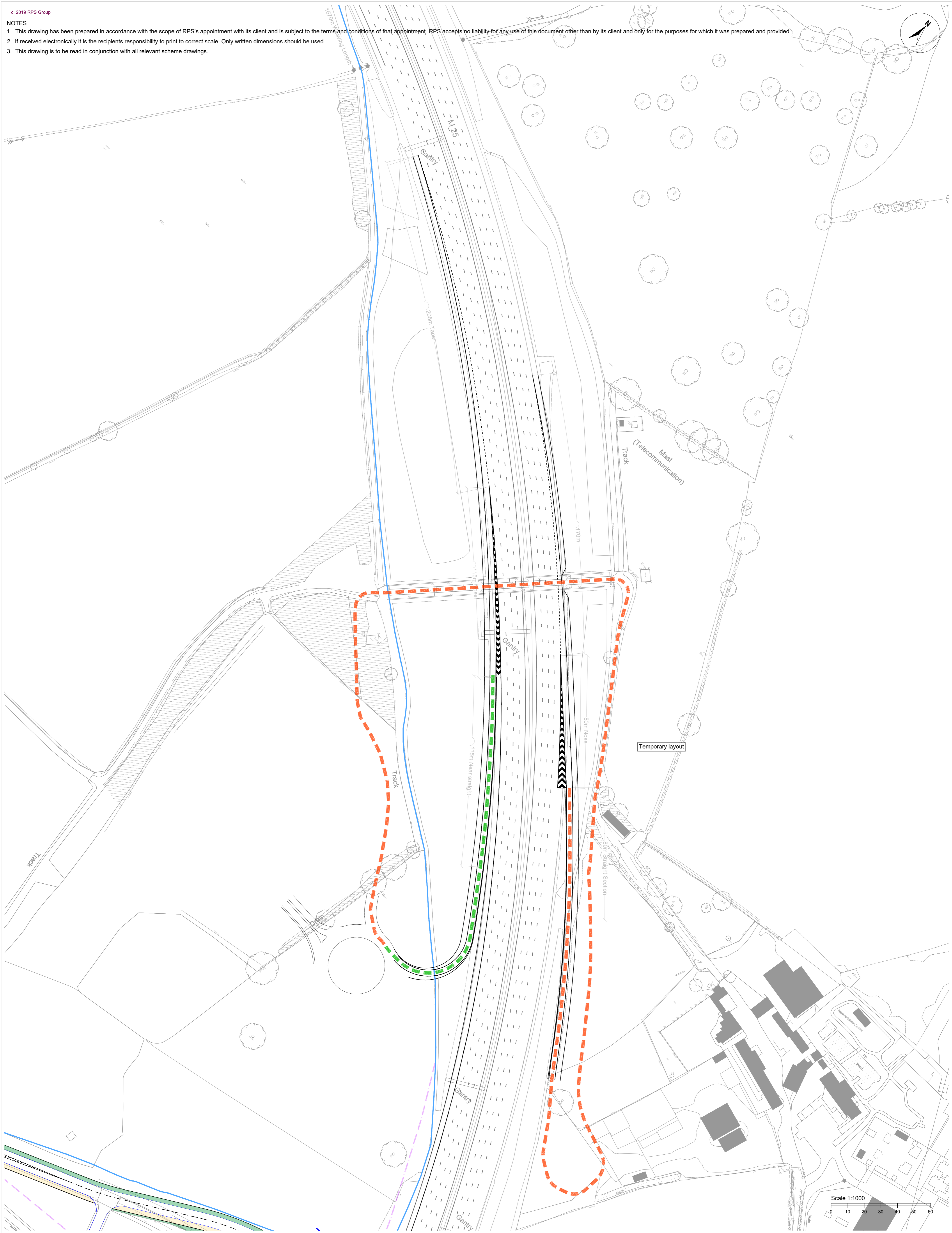

20 Farringdon Street, London EC4A 4AB  
T: +44(0)20 3691 0500 E: transport@rpsgroup.com

Client Welome Break Group Ltd

Project Iver MSA

Title Temporary Construction Access

Key:

	Access Route
	Egress Route

Status PRELIMINARY Drawn By AJ PM/Checked by ID

Project Number JNY10850 Scale @ A1 1:1000 Date Created 17/06/21

RPS Drawing/Figure Number JNY10850-16 Rev A

Rev	Description	By	CB	Date
A	Layout updated to Option 2 (drawing 26A)	AJ	ID	07/02/22

rpsgroup.com

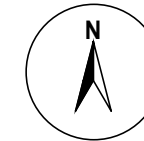

© 2019 RPS Group

**NOTES**

1. This drawing has been prepared in accordance with the scope of RPS's appointment with its client and is subject to the terms and conditions of that appointment. RPS accepts no liability for any use of this document other than by its client and only for the purposes for which it was prepared and provided.
2. If received electronically it is the recipients responsibility to print to correct scale. Only written dimensions should be used.
3. This drawing is to be read in conjunction with all relevant scheme drawings.

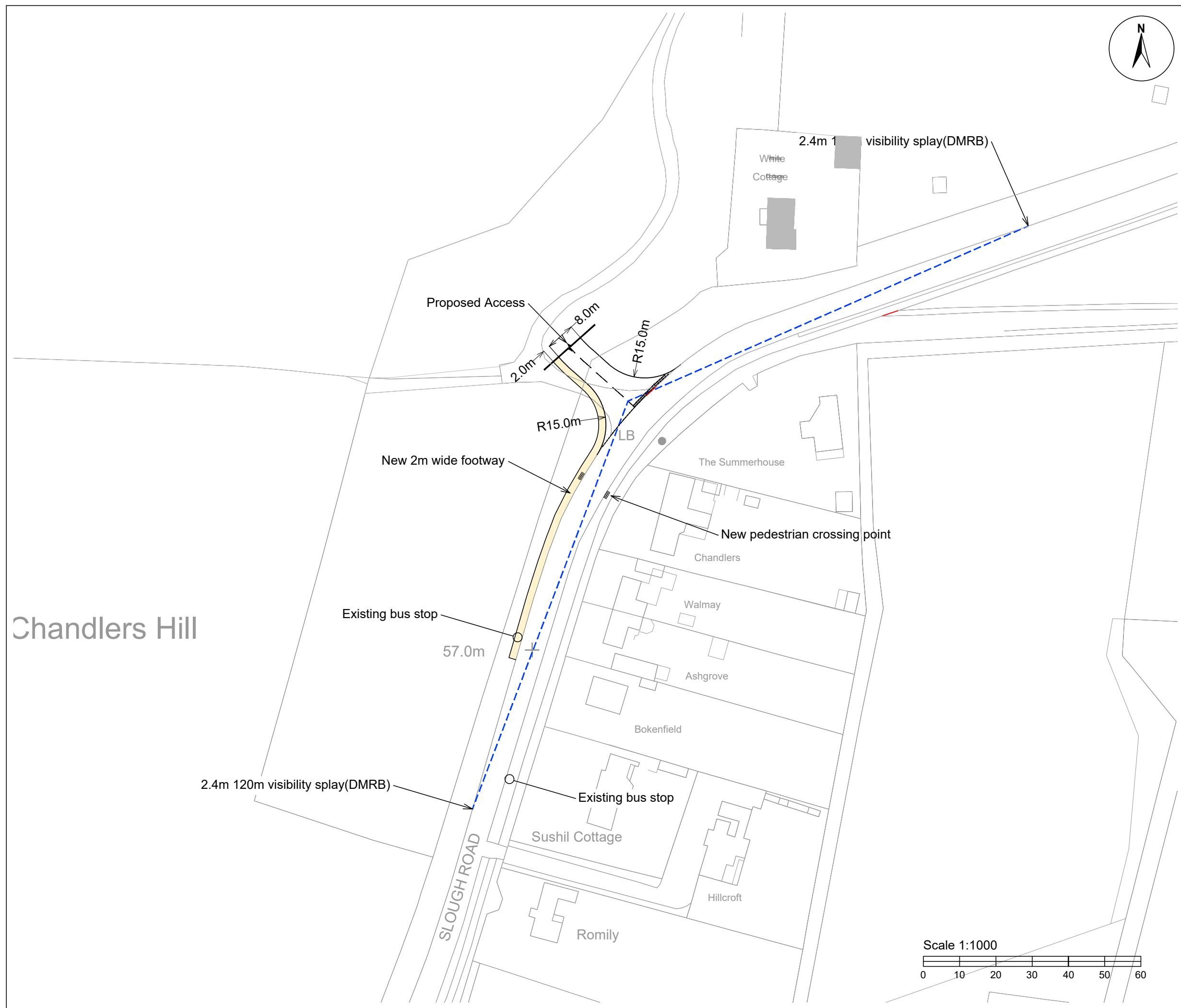

Rev	Description	By	CB	Date



20 Farringdon Street, London EC4A 4AB  
T: +44(0)20 3691 0500 E: transport@rpsgroup.com

Client **Welcome Break Group Ltd**

Project **Iver MSA**

Title **Slough Road  
Proposed Site Access**

Status	Drawn By	PM/Checked by
INFORMATION	AJ	MA

Project Number	Scale @ A3	Date Created
JNY10850	1:1000	12/05/21

RPS Drawing/Figure Number	Rev
JNY10850-07	-

[rpsgroup.com](http://rpsgroup.com)

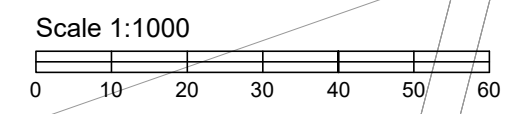

Changers Hill